



# FAR NE HEIGHTS MULTI USE OFFICE

EUBANK BLVD NE, NORTH OF SPAIN RD NE  
5528 EUBANK BOULEVARD NORTHEAST, ALBUQUERQUE, NM 87111



**FOR LEASE**

**AVAILABLE SPACE**  
1,200 - 5,000 SF

**RATE**  
\$13.00 - \$18.00 PSF  
Modified Gross

**Jeremy Salazar**  
jsalazar@resolutre.com  
505.337.0777

**PROPERTY HIGHLIGHTS**

- Excellent Visibility in desirable Far Northeast Heights
- Highly adaptable building; suitable to many uses
- Open floor plan suites
- Multiple options and configurations available depending on tenant's needs
- Tenant improvements available
- Large meeting space great for a church or conferences
- Monument signage available
- Modified Gross Lease: base rent plus utilities

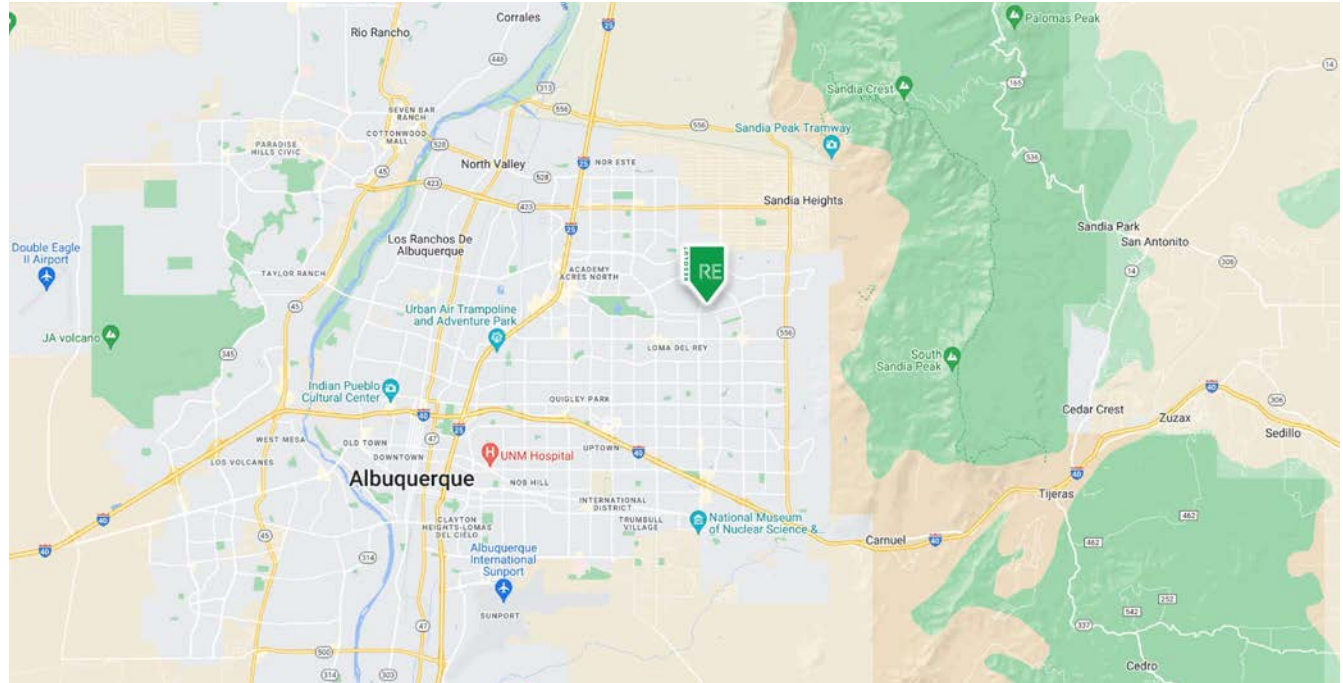

**AREA TRAFFIC GENERATORS**



**Jeremy Salazar**  
jsalazar@resolutre.com | 505.337.077

**DEMOGRAPHIC SNAPSHOT 2023**

 **121,246**  
**POPULATION**  
3-MILE RADIUS

 **\$125,334.00**  
**AVG HH INCOME**  
3-MILE RADIUS

 **81,250**  
**DAYTIME POPULATION**  
3-MILE RADIUS

 **TRAFFIC COUNTS**  
Eubank Blvd NE: 26,109 VPD  
(Sites USA 2023)

## PROPERTY OVERVIEW

This unique property is highly adaptable to many uses from educational, small fitness users, conference center, and traditional office users. Each room within Suite 5 has an open floor plan which can be customized to fit a tenant's needs. Suite 5 has the option of four different configurations ranging from 1,200 SF to 3,700 SF and can include a large common area conference space.

Suite 2 includes the common area conference space and a private classroom style room. This space is great for a weekend church or educational facility. The large conference area and common area restrooms are only available on evenings and weekends.

Suite 2 and Suite 5 can include monument signage on the highly trafficked Eubank Blvd NE.

## LOCATION OVERVIEW

5528 Eubank Blvd NE is a highly visible property situated between Spain Rd NE and Juan Tabo Blvd NE. Co-tenants include Balanced Physical Therapy, Ambrose Barber and Styling, Tutor Me K-12 tutoring services, Pegasus Massage, A Tax Solutions, Mayberry Senior Services, and New Mexico Early Learning Academy.

## PROPERTY OVERVIEW

SF:	1,200 - 5,000 SF
Zoning:	MX-T
Submarket:	Far Northeast Heights



**FAR NE HEIGHTS MULTI USE OFFICE | 5528 Eubank Blvd NE, Albuquerque, NM 87111**

## SUITE 2

- One dedicated room around 600 SF
- Large, Shared Conference Area 2,000 SF (Only available on evenings and weekends)
- Playground (Only available on evenings and weekends)
- \$1,750/Month

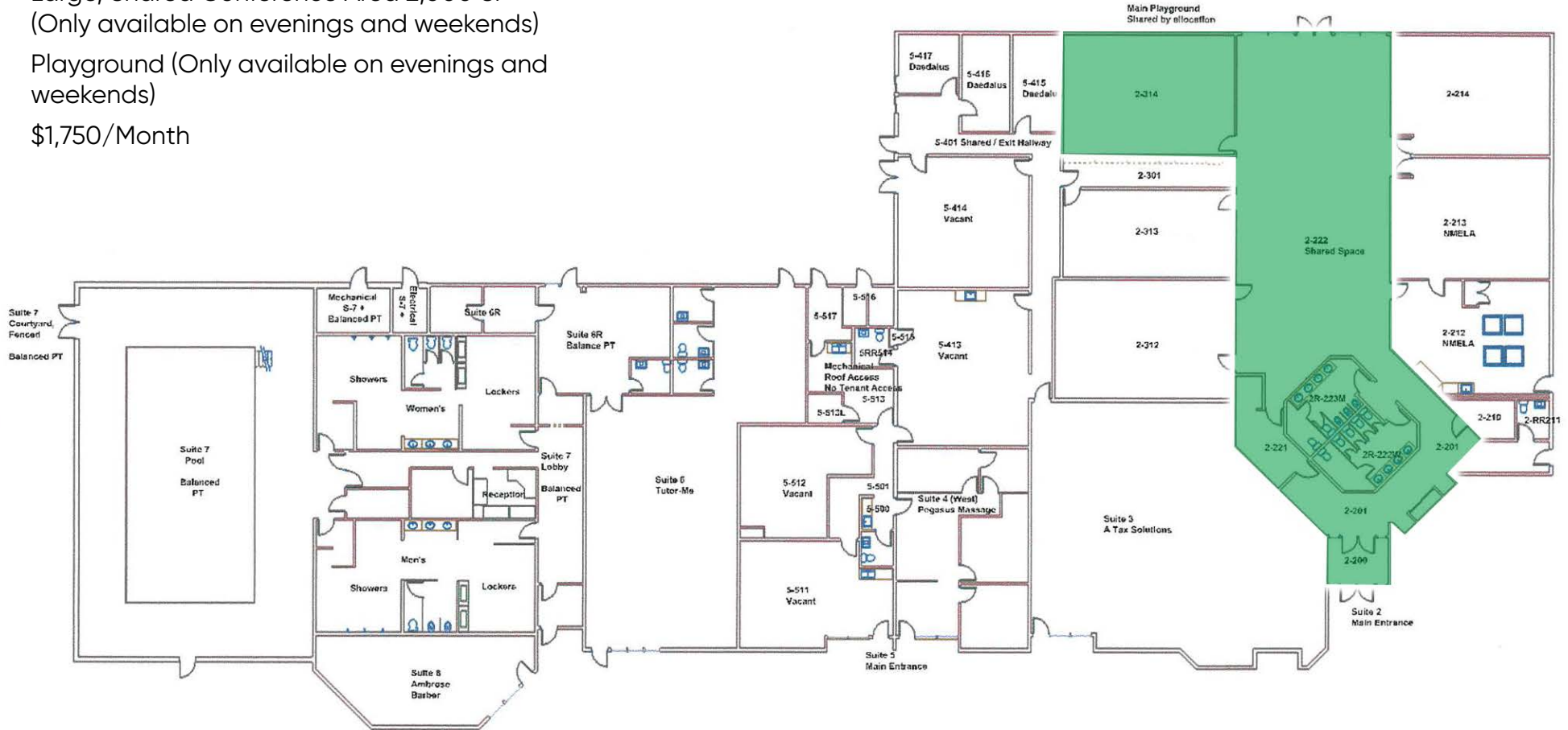

## SUITE 2



## SUITE 5 OPTION 1

- Five large rooms with great frontage and visibility
- Approximately 3,692 SF
- Starting at \$4,219 month modified gross plus utilities
- Option to Include:
  - Kitchen break area (additional \$525/Month)
  - 2,000 SF shared, Conference Area (weekend use) (additional \$1,100/Month)

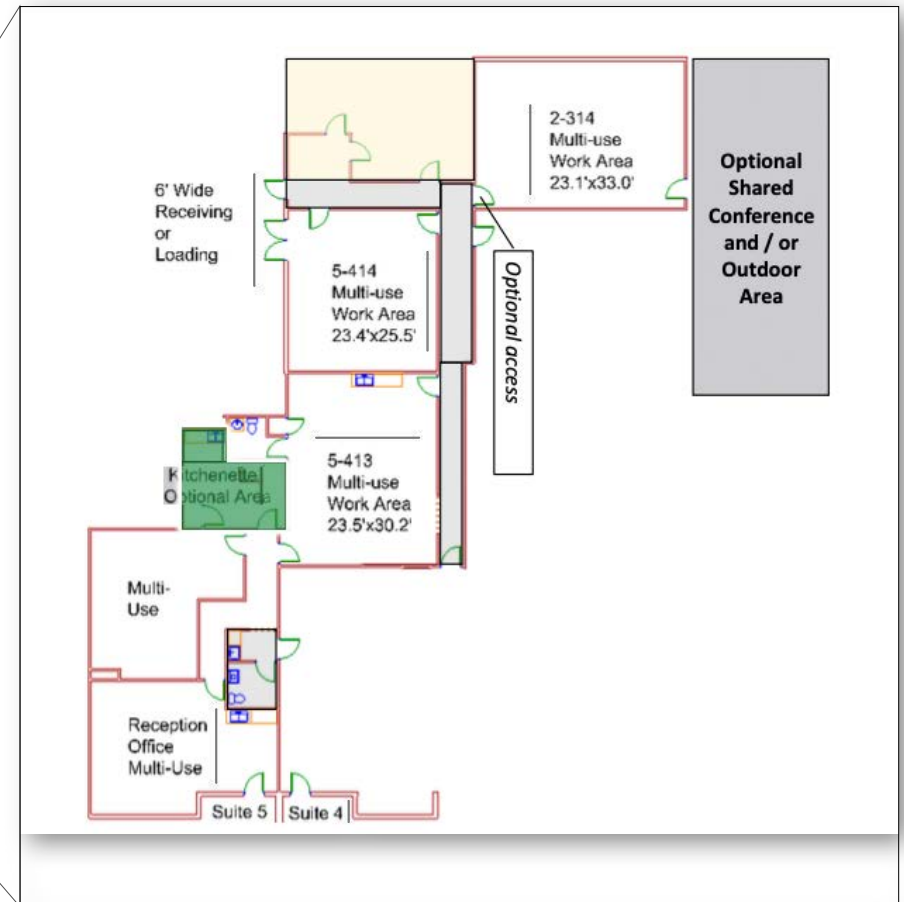
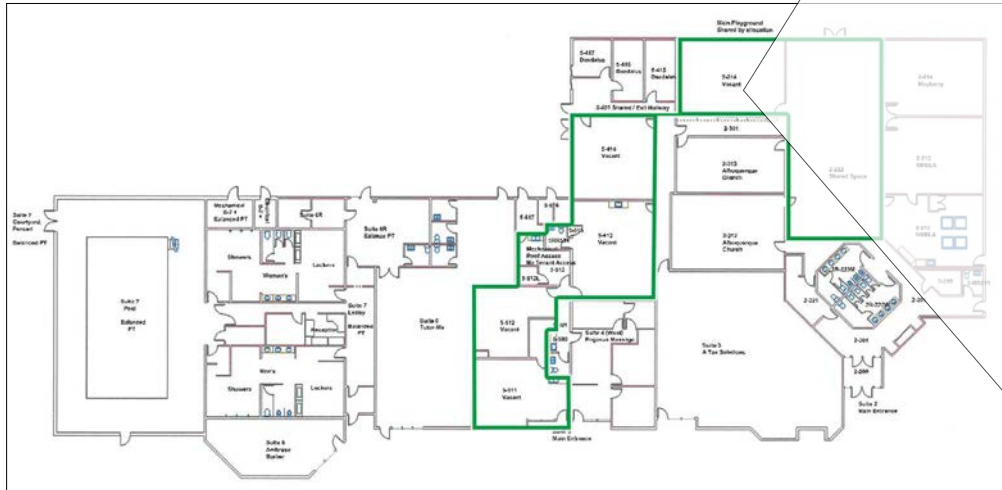

## SUITE 5 OPTION 2

- Four large rooms with great frontage and visibility
- Approximately 2,698 SF
- Starting at \$3,369 month modified gross plus utilities
- Option to add:
  - Kitchen break area (additional \$525/Month)

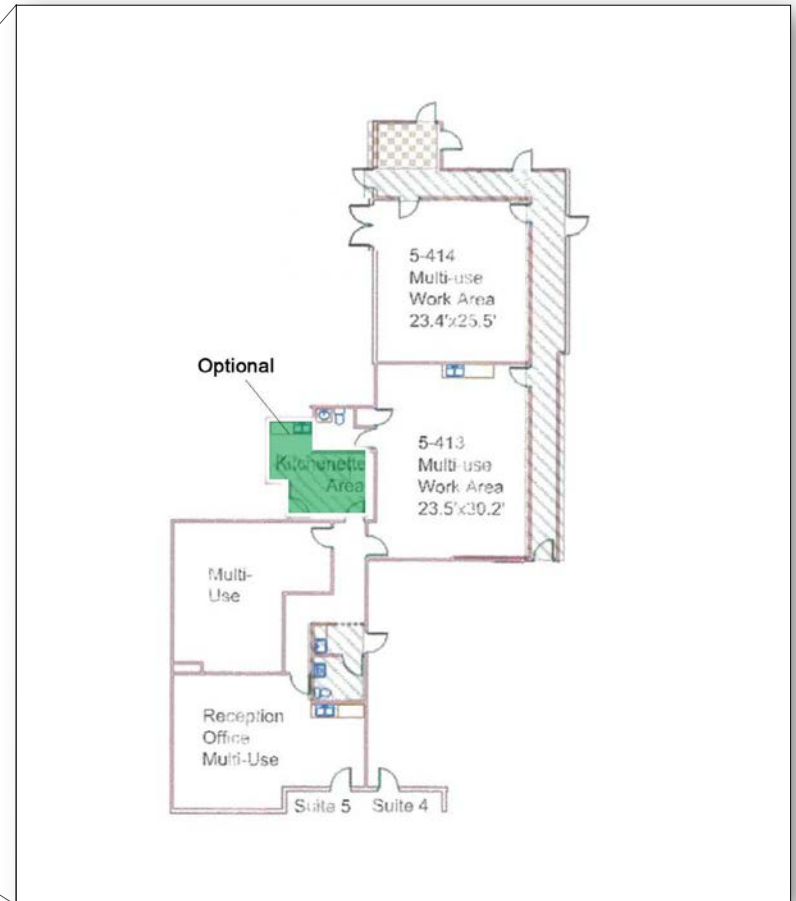
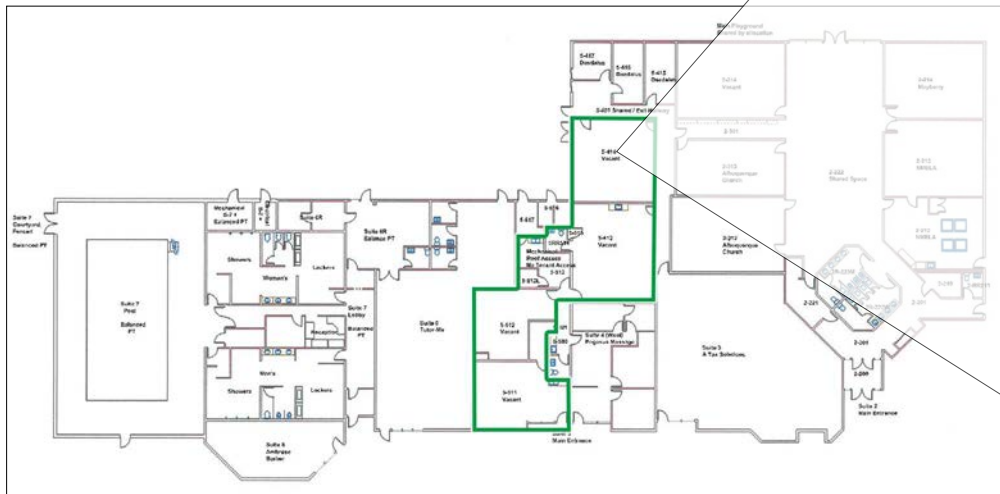



### SUITE 5 OPTION 3

- Three large rooms with great frontage and visibility
- Approximately ~2,072 SF
- Starting at \$2,599 month modified gross plus estimated utilities
- Option to Include:
  - Kitchenette (additional \$525/month)

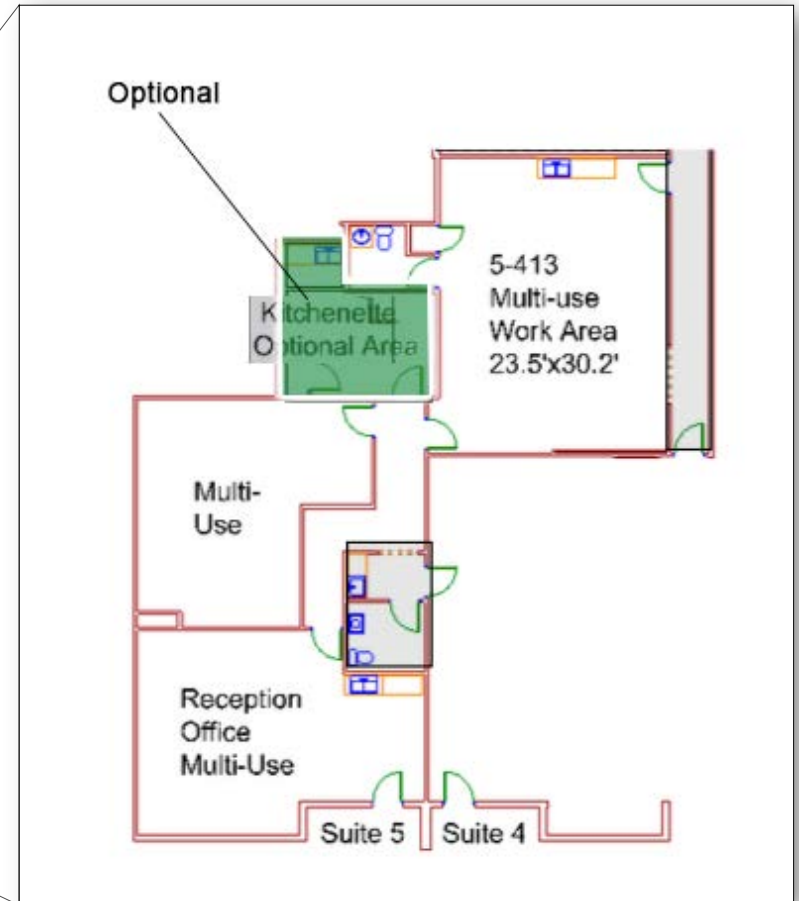
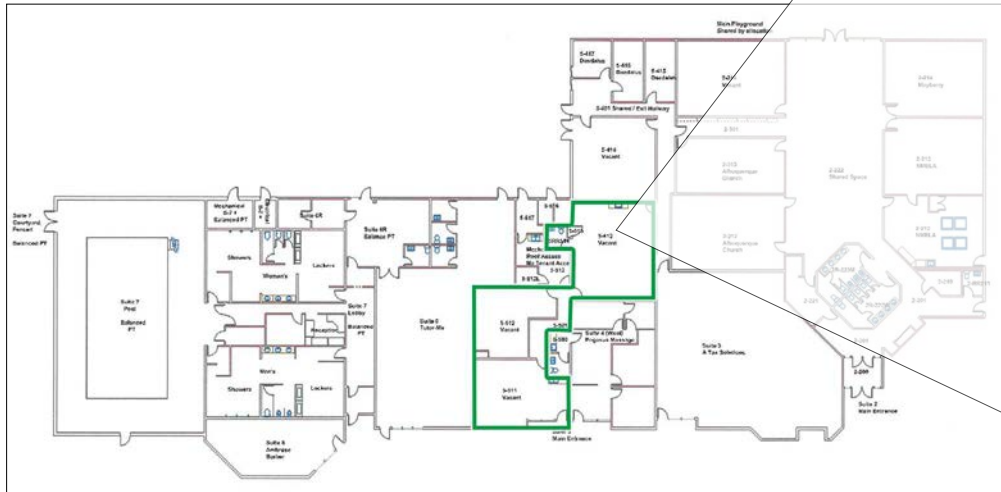

## SUITE 5 OPTION 4

- Two large rooms with great frontage and visibility
- Approximately ~1,268 SF
- Starting at \$1,629 month modified gross plus estimated utilities
- Option to Include:
  - Kitchenette (additional \$525/month)

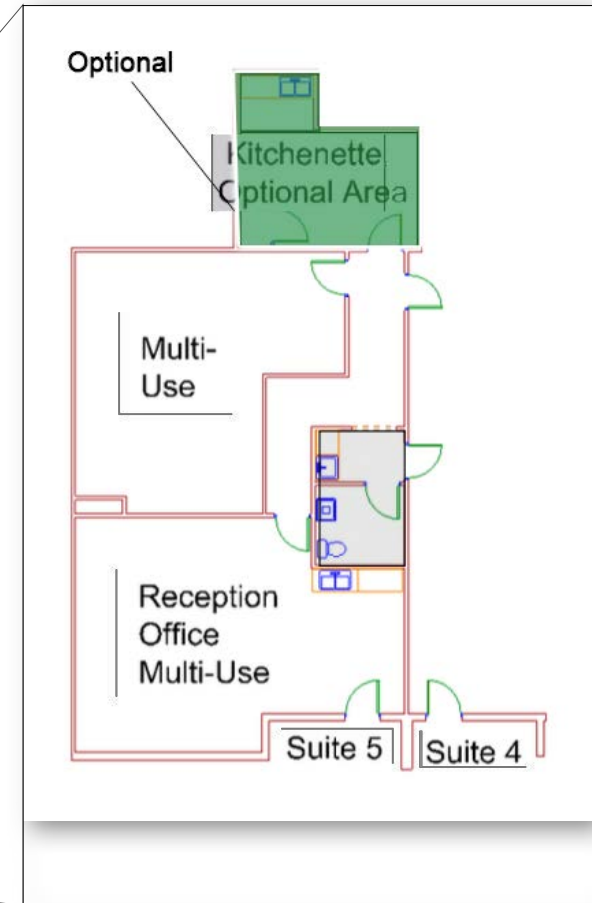
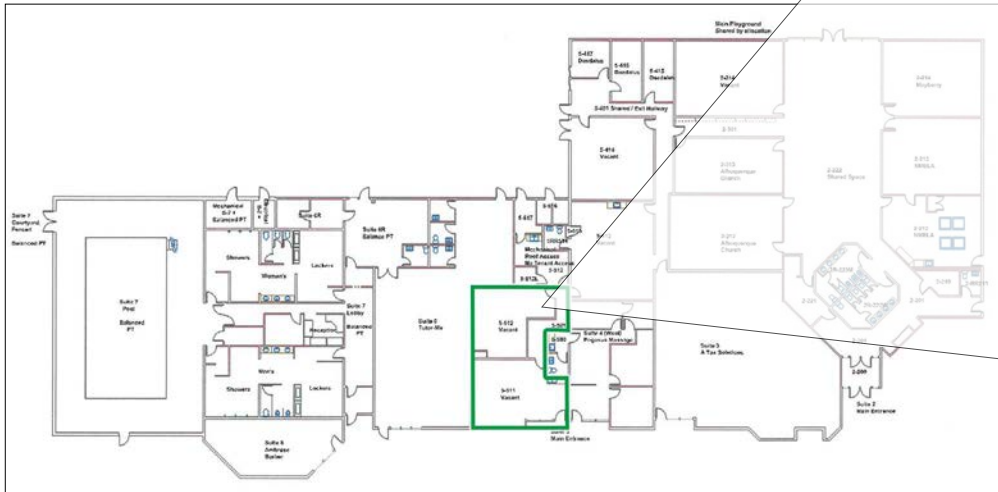

SUITE 5



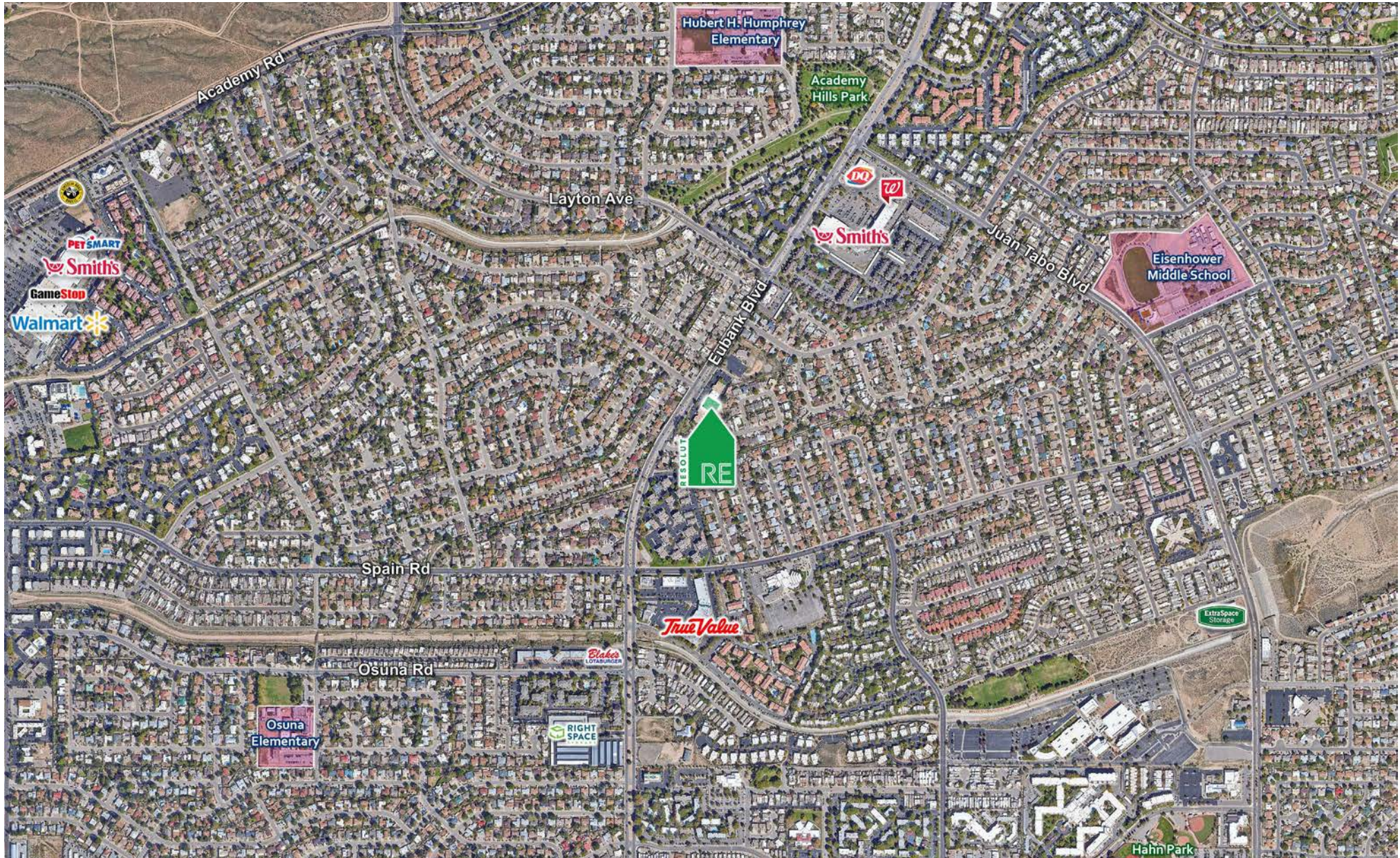

FAR NE HEIGHTS MULTI USE OFFICE | 5528 Eubank Blvd NE, Albuquerque, NM 87111

